

UNDERWATER LIGHT BULB IMPLOSIONS — A USEFUL ACOUSTIC SOURCE

Garry J. Heard¹, M. McDonald², N. R. Chapman², and L. Jashke²

¹Defence Research Establishment Atlantic, PO Box 1012 Dartmouth, Nova Scotia, Canada

²School of Earth and Ocean Science, University of Victoria, Victoria, British Columbia, Canada

Abstract — The implosion of sealed glass vessels — such as fishing floats, laboratory glassware, and various bottles — under the influence of hydrostatic pressure at depth in the ocean has long been known to produce moderately loud acoustic events. Common light bulbs have also been frequently used in practice, but it appears that the use of these particular vessels has not been described in the scientific journals. In fact, most users of light bulbs have no information on the crush depths, source level, and spectral content of the radiated signal. The aim of this paper is to remedy this shortcoming, to describe the use of common light bulbs as acoustic sources, and to provide guidance to researchers on the source level, spectrum, and usage of common sizes of light bulbs and fluorescent lighting tubes. With the current focus on shallow-water operations, bearing in mind the prohibition against the use of all but the smallest explosives, imploding light bulbs may be the most cost-effective acoustic source at depths under 300 m that minimizes environmental impact.

I. INTRODUCTION

Sealed glass vessels, including fishing floats [1], glassware and bottles [2], crushed under hydrostatic pressure have often been used as safe, moderately loud, broadband acoustic sources. Light bulbs have also been used as acoustic sources [3,4,5], but despite this popularity there does not appear to be any published data on light bulbs available at present. In addition, the measurements that have been made available have not been very extensive or complete. The purpose of this paper is to provide useful information that will aid experimentalists wishing to use imploding light bulbs as an acoustic source.

Interest in using imploding light bulbs as an underwater sound source has been growing recently. Since beginning this work the authors have received requests for information about light bulbs from a number of colleagues in four different countries. This increased interest is almost certainly due to the ever increasing restrictions on the use of explosive sound sources, particularly in the environmentally sensitive shallow-water areas that are the focus of much underwater acoustics research at this time. Light bulbs produce significantly lower source levels (SL) than even small explosives, but they at least partially fill the void left by the ban on the louder sources and they do so in an environmentally friendly manner.

The information presented in this report was collected from pressure tank tests in both the large and small pressure tank facilities at DREA, measurements made at the DREA calibration barge in Bedford Basin, and from measurements made during

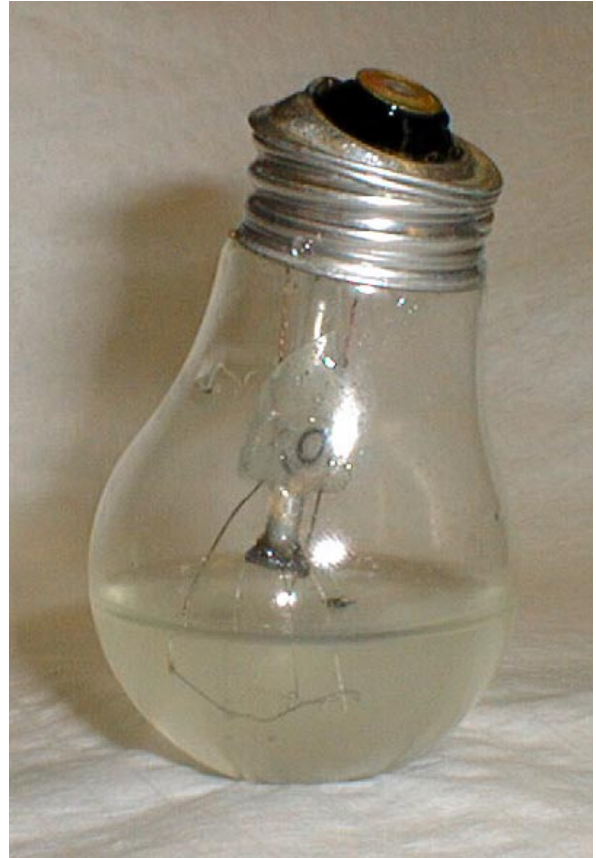

Fig. 1 Photograph of a ceiling fan bulb after pressure testing. Note the water inside the bulb and the crushed base where initial failure occurred. The central filament support 'exploded' under the pressure, but in this case it failed to break the bulb.

the recent Haro Strait and Trial Sable field tests. In addition to these new measurements, data from cited references is also included.

Pressure tank tests on a number of different types of light bulbs have been conducted to determine the expected crush depths and the degree of variability. Examination of the implosion fragments also revealed a surprise with regard to the failure mode of many types of bulbs (see Fig. 1 – note the deformation of the base and water inside the bulb). It appears that most of these bulbs fail by water penetrating the base of the bulb and exploding the central filament support. Shrapnel from the filament support appears to break the glass near the base of the bulb and catastrophic failure results. The fragments tend to be relatively small, ranging from 1 — 30 mm in length and 1—10 mm in width. Occasionally, bulbs will survive the explosion of the

central filament support as shown in Fig. 1, especially the ceiling fan and decorator globe types, and the result is a water filled bulb that radiates only a relative weak acoustic pulse. Larger bulbs, including the larger variety of 150W bulbs and 500W bulbs, tend to break initially where the glass is concave in the region between the base and globe, rather than at the filament support. The 500W bulbs often break in very large fragments leaving much of the globe portion intact. Fluorescent tubes tend to break into fragments of various sizes and shapes that range from the entire length of the tube without the endcap sections down to sand-like particles. The size of the debris depends on the failure pressure and probably reflects the various manufacturing processes these tubes have undergone.

A number of light bulbs were tested at the DREA calibration barge. Some of these tests were informally conducted and only the peak voltage and/or the peak spectrum level of the light bulb implosion signal was noted. For other tests conducted at the calibration barge a Hewlett-Packard spectrum analyzer and B&K monitor hydrophone were used to sample the implosion waveform at 256 kilo-samples/second and the resulting data was saved on floppy disks for further analysis. All of these tests were conducted with a mechanical light bulb breaker that was lowered to known depths.

Light bulbs were used during the recent MIT/UVIC Haro Strait and DREA/UVIC/SACLANTCEN Trial Sable experiments. Both of these experiments employed vertical line array (VLA) receivers. Neither of these data sets were specifically designed to collect light bulb implosion data, the bulb detonations were used for array element localization, array tilt measurements, and as convenient test signals to confirm sensor operation. The results from the MIT/UVIC experiment are identified by referring to them as the Haro Strait data, while the results from the DREA/UVIC/SACLANTCEN experiment are referred to as the Heard data. Sampling rates were 1750 Hz for the Haro Strait data and 2048 Hz for the Heard data. An additional data point was recorded by McDonald using a sonobuoy receiver. This data was sampled at 22300 Hz and is identified in the figures as the McDonald data.

Finally, some additional information is presented in this report that was collected by other researchers. In particular, light bulb data collected by Gabrielson of Pennsylvania State [3] and Shockley of NCCOSC RDT&E Div. [4] is of particular note. Useful information was also obtained from a presentation by Marshall [5] at the 126th meeting of the ASA.

In the following section, light bulb physical data are presented, Section III presents the measured waveform of a light bulb implosion, Section IV presents the spectral data for various types of light bulbs, Section V presents the source level measurements, Section VI discusses various methods of light bulb deployment, Section VII discusses the variability in measured parameters of light bulb implosions, and finally conclusions are presented in Section VIII.

II. PHYSICAL DATA

Table 1 summarizes the results of the pressure tank tests on various types of light bulbs. Incandescent bulbs appear above the heavy line in the table and fluorescent types appear below

the line. Glass thickness was measured from the debris collected after each pressure test. The stated values are either typical values in the middle of the thickness range or they are the minimum and maximum values.

Nominal cold resistance values of the bulb filaments are also quoted where available and applicable. The filament can be useful in determining the implosion instant for the 150W and smaller bulbs, but the user should be aware that the filament does not always break and that the filament supports often become tangled in the implosion thereby re-closing the circuit.

The volumes quoted in Table 1 are approximate. The volume of the smaller bulbs was obtained by measuring the displacement in a graduated container. The fluorescent tube volumes were obtained by direct measurement of the bulb dimensions. All of the quoted values are therefore total volumes and do not directly relate to the volume of gas contained within the bulbs due to the unknown volumes of glass, bases, and internal structures.

The approximate internal pressures of some bulbs are quoted in Table 1. These values were determined by just submerging the bulbs in a bucket of water and drilling a very tiny hole through the glass while the bulb was submerged. The weight of the bulb was measured before and after the water was sucked in through the hole. The amount of water that ran into the bulb was assumed to be sufficient such that the gas pressure inside the bulb was altered to approximately 1 atmosphere (101.36 kPa). Using the equation of state and the measured bulb volumes it was possible to obtain a rough estimate of the original gas pressure.

Inspection of the failure pressures in Table 1 reveals an immediate problem with using light bulbs as an acoustic source; the failure pressures show a considerable degree of variability for each type of bulb. This variability means that free-falling bulbs of the same type will not all implode at the same depth. It is also clear that the brand of bulb can be important if the water depth is limited (as it often is) or if the implosion is required to be relatively deep. The values quoted in Table 1 are excess pressures, that is, pressure above 1 atmosphere.

Another factor effecting the choice of particular light bulbs is the failure mode. The tougher bulbs, such as the decorator globe type, the ceiling fan, and appliance bulbs are better suited for use in bulb breaking devices that ensure the glass vessel is completely broken. These bulbs occasionally remain intact and the radiated noise is significantly reduced when this occurs. Cheaper bulbs tend to break at slightly lower pressures than more expensive bulbs and are therefore best suited for work in shallow-water.

III. TIME SERIES

The waveform of a Sylvania 100W A19 type bulb broken in a mechanical breaking device is shown in Fig. 2. This bulb was held at a depth of 18.3 m and the implosion waveform was received with a B&K 8106 calibrated hydrophone and recorded on floppy disk with a sampling rate of 256 kHz using a Hewlett-Packard spectrum analyzer with a 14-bit A/D.

The waveform sampling was triggered from the activation of a relay in the mechanical light bulb breaker. The relay and the hammer mechanism of the bulb breaker are responsible for

TABLE 1.
Physical data for various light bulbs. Failure pressures quoted are pressures above 1 atm.

Bulb Type	Wattage (W)	Cold Filament Resistance (Ohms)	Failure Pressure (kPa)	Volume (mL)	Weight (g)	Glass Thickness (mm)	Internal Pressure (kPa)
SYLVANIA (A19)	60	15.9	896	150	27	~0.56	77
SPECTRO (A19)	100	10.3	2413 1965	150	28	~0.76	87.2
GE I-line	500	2.0	241 414	1350	146	~0.51	83.1
SYLVANIA A23-1C-6000H	150	7.1	1207 1551 758*	250	43	0.36-0.89	75
PHILIPS Extended Service 2500H	150	8.4	690	200	33	0.43-0.69	82.1
SYLVANIA PS3578-0017-607H	500	-	469	1000	125	0.64-1.14	
GE40A15/F/PM CD	40		3344	90	23	0.64-0.89	
GE40A/CF/PM CD2	40		2034	85	23	0.64-0.89	
GE1 016 G25 Decorator Globe	40		2999	280	43	0.51-1.07	
CGE Decorator Globe	60		1069	300	40	0.30-0.99	
NCGE192SW1	25		896 827 1241	160	29	0.46-1.09	
Canadian Tire (A19)	40	24.2	724 793 <552 ⁺ 793	160	29	0.56-1.07	81.1
SYLVANIA 2 ft. F24T12/CW	21	-	1282 986	600	141	~0.81	~10.1
GE 4 ft. F40D	34	1.7	883 1055	1340	261	~0.74	
SYLVANIA 8 ft. F96T12/CW	110	0.7	1324 1227	2650	563	~0.79	
VITA-LITE DURA-TEST	34	1.9	1289	1342	299	0.84-0.91	
PHILIPS F400x/RS/EW	34	1.9	-	1293	256	~0.71	

* very fast pressurization, possible pressure spikes

⁺no implosion, globe cracked

the high frequency noise preceding and slightly overlapping the higher amplitude bulb implosion signal. A surface echo of the relay trigger appears at about 22 ms in the record. The implosion waveform shown in Fig. 2 is quite symmetrical which indicates that the bubble oscillations are relatively small and the non-linearity of the process is minimal.

Most standard light bulbs used in homes will contain an argon-nitrogen mixture at a pressure that is estimated to be in the range of 75—85 kPa. At 18.3 m depth the ambient pressure is approximately 283 kPa, so the water initially compresses the freed gas bubble. Following Strasberg [6] the instantaneous sound pressure radiated by a bubble is proportional to the second time derivative of the bubble volume. The initial radiated signal (see Fig. 1) corresponds to a rarefaction as the water rushes

inward to fill the volume occupied by the gas once contained in the light bulb. At first the inward velocity of the surrounding water increases in time giving rise to an increasingly negative external pressure. Soon the bubble has been compressed sufficiently that the inward rush of water is impeded and the external pressure begins to increase. When the external pressure equals the ambient pressure the bubble size is at a minimum. After this the bubble begins to expand and the outward fluid velocity and the radiated pressure increase rapidly. As the bubble size increases, the internal pressure reduces and the outward fluid velocity begins to decrease. The maximum bubble size occurs when the external pressure equals the ambient pressure (i.e. at the zero crossing). The whole process is then repeated a number of times with decreasing amplitude as energy is lost from the

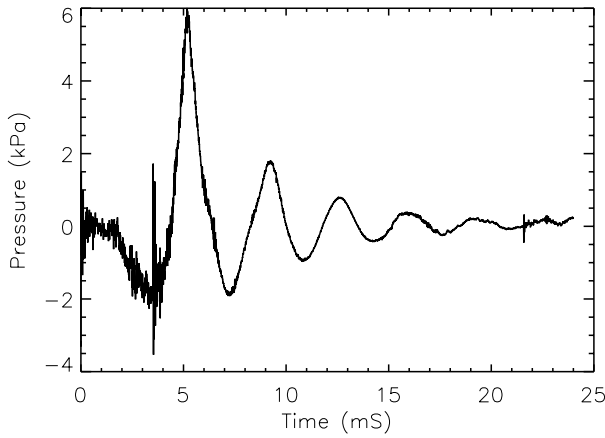

Fig. 2 Time series of a 100W light bulb imploding at a depth of approximately 18.3 m. This waveform was sampled at 256 kHz.

oscillation. The decay of the signal envelope is well described by an exponential decay.

Four Sylvania 6000H light bulb implosions were video-taped in a 5 m deep tank to observe bubble behaviour. The implosions were recorded with a standard video camera and VHS recorder so that the frame-rate was far slower than desirable, but some interesting observations were still possible. The initial break in the bulb, even at the low pressure at 4 - 5 m depth, results in a rapid inflow of water and the entire volume of the bulb is obscured by very fine bubbles and vapour. Fine strands of bubbles are observed extending from the central region of the implosion. From the timing of the low frequency oscillations following the bulb break, it appears that all of the low frequency energy is emitted while the gas is initially confined to a volume just slightly larger than the original light bulb. The duration of the low frequency emission is depth dependent with the duration decreasing with increasing ambient pressure. At 13 m depth the duration is approximately 70 ms, at 18.3 m depth we see that the low frequency emissions remain significant for about 25 ms, but from at sea measurements we find that the duration of the low frequency emissions reduces to 8—12 ms at a depth of 120 m. Very roughly we find that for A19 sized bulbs the duration of the low frequency energy varies according to $hT = 700$, where the h is the depth in metres and T the duration in ms.

After just a few tens of milliseconds the bubbles appear to have grown in size and begun to rise. One bubble forms which is larger than the rest. This larger bubble appears to be a vortex that moves quickly through a cloud of smaller bubbles. The formation of the vortex is probably due to the motion of the bulb breaker hammer. In less than a second the bubble has moved at least 30—50 cm and it begins to break up into a cloud of much smaller bubbles. The smaller bubbles last for a much longer period and eventually reach the surface. It is possible that the sound emitted by the implosion will reflect a time variation in the frequency content due to bubble size variations.

IV. SPECTRAL DATA

The solid line in Fig. 3 shows the energy flux density at a distance of 1 m for the windowed direct-path arrival shown in

Fig. 2. The time-series was windowed to eliminate the high frequency noise at the start of the data (caused by the breaker mechanism) and the surface reflection at the end of the data. The primary bubble resonance occurs at a frequency of approximately 242 Hz and is by far the dominant spectral component. The equivalent noise spectrum is shown by the dashed curve. The noise levels are at least 20 dB below the implosion signal at all frequencies.

Fig. 4 shows the energy flux density of three different implosion events from the Heard data set. All three spectra were calculated using a half-second long data segment. This interval includes the direct-path arrival energy and multiple bottom and surface reflected arrivals. The resulting spectral levels show interference effects and are somewhat lower than they would be if just the direct-path arrival had been analyzed.

The solid line in Fig. 4 represents the spectrum levels of a 100W light bulb that imploded at a range of 427 m from the receiving VLA. The bulb is estimated to have imploded at a depth of 144 m. The data acquisition system sampled at 2048 Hz and has an 800 Hz anti-aliasing filter. The filter roll-off is very apparent in the spectra shown in Fig. 4. Unfortunately, the primary resonance of the bulb implosion appears to occur just above the anti-aliasing filter 3 dB cutoff point at a frequency of 833 Hz; therefore, the spectrum does not show the true peak of the radiated energy.

The dotted curve in Fig. 4 shows the energy flux density of a GE 500W bulb that imploded at a range of approximately 1213 m from the VLA. The implosion depth of this bulb has not been determined, but it is likely that it imploded somewhere in the depth range of 30—70 m. The primary resonance occurs at a frequency of about 200 Hz and four harmonics are seen within the available bandwidth. The peak spectral level is more than 20 dB greater than that for the 100 W (A19) bulb.

The dashed curve shows the energy flux density of an imploding 2-foot long Sylvania fluorescent tube. This tube was deployed at a horizontal range of 689 m from the VLA receiver. The crush depth for this event has not been determined from the acoustic data. Fluorescent tubes emit strong broadband energy. Informal tests at the calibration barge indicate that the radiated signals possess substantial energy over a band several kilohertz

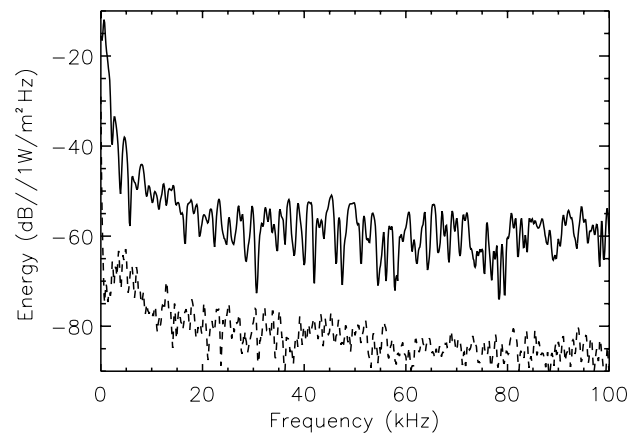

Fig. 3 Solid line represents the energy spectrum of the implosion shown in Fig. 2. Dashed line is the equivalent noise energy at time of measurement.

wide, only a fraction of which is visible in Fig. 4; however, the bulk of the available energy is contained in the first kilohertz. An interesting observation is that the energy flux density was calculated for five different fluorescent tube implosions: 2 - two foot tubes, 2 - four foot tubes, and 1 - eight foot tube. All of these implosions, except for one, produced very similar spectral shapes and levels despite the wide variation in the gas volumes. This result is very different than what is observed with incandescent bulbs of different sizes. A possible explanation for this observation is that the long thin gas cylinder produced initially by a fluorescent tube tends to break up much more than the nearly spherical bubble produced initially by an incandescent bulb. The distribution of bubble sizes would likely be similar despite the differing gas volumes in the different tube sizes. The similar spectral levels may be due to the incoherent oscillation of the individual bubbles, but this part of the explanation is far less certain. The single event that produced a unique spectrum was likely indicative of a different mode of failure.

All of the available data on the primary resonant frequency of A19-sized and near A19-sized bulbs is plotted versus the implosion depth in Fig. 5. The solid curve in Fig. 5 represents the theoretical resonant frequency for a volume pulsation of a bubble under hydrostatic pressure. The frequency, f , is found to be

$$f \propto (g(h+10))^{5/6}, \quad (1)$$

where g is the gravitational acceleration in m/s^2 and h is the depth of the implosion in metres. This relationship can be easily derived using Minnaert's [6] expression for the volume pulsation frequency of a bubble of radius R_0 and using Boyle's Law to predict the bubble radius with a given hydrostatic ambient pressure. Since we do not know the exact constituent gases and pressures inside a light bulb, the best we can do is to fit the depth variation in (1) to the measured frequencies as shown in Fig. 5.

Over the depth range for the light bulbs tested this proportionality does not depart significantly from a linear variation with depth.

V. SOURCE LEVEL

In this section we present measurements of the intensity of imploding light bulbs. Several researchers [3,4,5] have measured the peak SL from recorded waveforms of imploding light bulbs. The peak SL's that have been measured are indicative of the overall intensity of the emitted sound, but unfortunately most of the measurements made to date were done incidental to other experiments and the sampling rates that were employed were generally far too low to delineate the peak accurately. The only useful known exceptions to this sampling inadequacy were the data collected at the DREA calibration barge where the sampling rate was 256 kHz and some measurements made earlier by Shockley [4].

One observation that appears to be linked to the generally inadequate sampling rates employed is that there has been confusion over which part of the radiated implosion signal has the greatest peak amplitude. The highspeed sampling recordings, like that shown in Fig. 2, all indicate that the initial rarefaction in the surrounding medium is generally not as high in amplitude

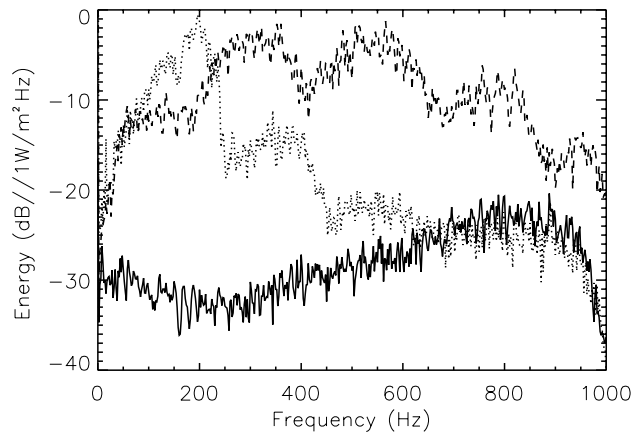

Fig. 4 Comparison of the energy flux density spectra for three different types of light bulbs. The solid line is the spectrum for an A19 sized 100 W bulb, the dotted line is the spectrum for a 500 W GE I-line bulb, and the dashed line is the spectrum for a Sylvania F24T12/CW fluorescent tube.

as the immediately following compression portion of the oscillation cycle, at least at the relatively shallow depth at which these recordings were made. The more slowly sampled sea test data do indicate that as the depth of implosion increases, then so does the amplitude of the primary (rarefaction) peak. At 100—200 m depths it appears that the primary peak can be as large, or larger than, the second peak. This makes sense, as the greater the external ambient pressure, the faster the bubble walls will accelerate inwards giving rise to an increasingly larger negative external pressure signal as the implosion depth increases.

Fig. 6 shows the collected measurements of peak SL versus depth of implosion for A19 sized bulbs. Both freely falling and suspended, mechanically broken implosion events are included. The bold line fitted to the data is given by

$$SL = 160 + 26 \log(h), \quad (2)$$

where the depth h is in metres. This relationship implies that the SL increases more rapidly than the square of the ambient pressure at the depth of the implosion.

Table 2 provides details of the SL measurements made during the current investigation of light bulb acoustic sources. Some of the measurements that are listed were informal measurements and some others were light bulbs that were deployed during a sea test before there was particular interest in making quantitative measurements of implosion parameters. For these particular events the brand of light bulb was not always known. The SL values listed represent the peak acoustic levels unless they are marked (x) in which case they are the peak spectral level for the primary resonance.

To complement the peak SL measurements just presented, the energy flux density for implosions of a 100W A19-sized bulb, a large 500W bulb, and a two-foot long fluorescent tube are presented in Fig. 4. The use of the integrated energy flux is a much more common way of presenting the SL for transient acoustic sources than the peak SL and allows direct comparison of the energy in a light bulb implosion with published values for ex-

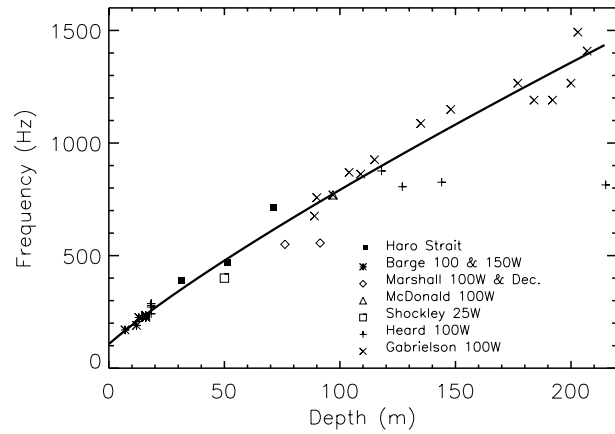

Fig. 5 Observed primary resonant frequency-vs-depth for A19 and near A19-sized bulb. The solid line represents the best fit of (1).

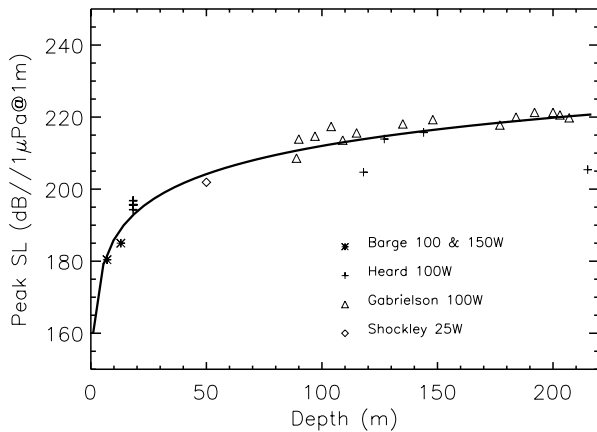

Fig. 6 Observed peak SL-vs-depth of implosion for A19 and near A19-sized bulbs. The solid line represents an approximate fit given by (2).

plusive sources. The SL of a 0.82-kg SUS (signal underwater sound charge) at 194 m depth is approximately 58 dB/1 erg/cm²/Hz [7,8] at the spectral peak near 50 Hz, this corresponds to 28 dB/1 W/m²/Hz. From inspection of the levels in Fig. 4 it is clear that light bulbs generate far less acoustic energy than even small explosive charges—anywhere between 500 and 100,000 times less energy depending on the size of the bulb.

The energy flux density can be integrated to give the total energy flux and this quantity can be compared to the work done to sink the bulb to the implosion depth. The resulting ratio is the radiation efficiency. This efficiency is generally quite small. For the A19-sized bulbs tested, the efficiency (in the 800 Hz pass-band of the data acquisition system) is typically about 3.5%. This value compares well with the efficiency found by Shockley [4] who found the value to be 4.5% ± 1.4%. When efficiency is calculated for the 18.3 m implosions sampled at 256 kHz, the efficiency is found to be approximately 11.5%, it appears that the radiation efficiency is greater at lower ambient pressures and the inclusion of energy in the 1—100 kHz band is significant.

TABLE 2
Source level measurements made during this study.

Bulb Type	Depth (m)	Primary Resonance Frequency (Hz)	Peak Source Level (dB//1μPa@1m)
100 W (A19)	13	225	160 ⁺ (185)
100 W (A19)	16	235	160 ⁺
Philips 150 W	16	225	162 ⁺
Philips 150 W	16	230	161 ⁺
Philips 150 W	7	170	159 ⁺ (180)
Philips 150 W	12	190	160 ⁺
GE I-line 500 W	16	130	176 ⁺
GE I-line 500 W	16	135	178 ⁺
GE Flr. 4 ft. 34 W	16	205	167 ⁺
GE Flr. 4 ft. 34 W	16	255	168 ⁺
GE40A/CF/PM CD2	18.3	285	188
Sylvania 100 W A19	18.3	272	197
GE40A/CF/PM CD2	18.3	385	191
GE40A15/F/PM CD	18.3	323	192
Can. Tire 40W A19	18.3	223	198
Can. Tire 40W A19	18.3	213	199
SPECTRO 100 W	18.3	279	196
NCGE192SW1	18.3	287	194
Sylvania 100 W A19	18.3	242	196
100 W (A19)	118	876	205 ⁺
100 W (A19)	215	814	205 ⁺
100 W (A19)	127	806	214
100 W (A19)	144	826	216
100 W	97	770	175 ⁺

⁺overloaded signal

VI. DEPLOYMENT

In this section we discuss the actual deployment of light bulb acoustic sources. The manner of deployment usually depends on the purpose that the light bulb implosion data is intended for. Often, researchers simply need a brief transient acoustic source to determine that receiving arrays are functioning, or perhaps, to determine that sensors are connected with proper polarity. Free-falling light bulbs are well suited to this type of situation and this undoubtedly represents the manner in which almost all light bulbs deployed to date have been used. Many researchers have made a habit of collecting rocks on the shore or rusty nuts and bolts that are simply tied to the light bulb as it is about to be tossed over the side of the research vessel. The problem with this approach is that the descent time of the bulb is never known and this usually results in difficulties in the laboratory when the implosion may occur 10 seconds or two minutes after deployment. To overcome this problem we have experimented with various light bulb sinkers that can be made in quantities, cheaply and easily, and remain as environmentally friendly as possible.

Fig. 7 shows an assortment of sinkers that were tested in our



Fig. 7 Various light bulb sinkers made from plaster and other materials. The sinker second from the right in the back row is the current favourite.

calibration tanks at DREA. The sinkers were made of various materials: plastic, plaster, cement, and lead shot. The sinker in the back row, second from the right is the current favourite. This sinker is composed of plaster with a moulded screw thread at the top, and 230 g of lead shot encased in the plaster at the bottom end. The sinker is 5.7 cm in diameter, 25.5 cm tall, and weighs 714 g when fully dry. This sinker falls almost vertically at a rate of approximately 1 m/s with an A19-sized bulb screwed into the thread on the top end. We plan to make extensive use of this sinker during an upcoming sea test. If it is found to be useful, some further modifications will be made, the first of which will be to substitute iron shot for the lead. Ideally a faster sinker rate is desired than this sinker can provide. Streamlining the sinker body can speed the descent (see third from right in Fig. 6) even without using the additional weight provided by the lead shot; however, it was discovered that asymmetries in the sinker bodies caused the sinker to ‘sail’ in a complicated path with the result that the implosion might occur many metres from a point beneath the drop location.

While freely falling bulbs have often been used for array tilt or shape estimation experiments, the difficulties in knowing the exact range of the bulb to the receiver and the exact depth and moment of the implosion can lead to undesirably large uncertainties in the results. When precise results are required or when the bulb must be broken at a depth less than the nominal crush depth of the light bulb it becomes necessary to use a mechanical device to break the light bulb. Here we present two mechanical bulb breakers that fill different needs. Fig. 8 shows a light weight bulb breaker that is cheaply and quickly made. The device uses a heavy-duty fishing reel and line to suspend a bulb at any depth. The bulb is imploded by dropping a ‘messenger’ down the fishing line. The messenger is typically a length of iron pipe or moulded lead that travels down the line and impacts a blunt spring loaded plunger that is driven into the bulb when the messenger hits. This arrangement allows bulbs to be imploded at selected depths with reasonable accuracy. It is easy to use, cheap to make, and can be reloaded relatively quickly. It is well suited to deployment from small boats. Unfortunately, it does not allow the implosion instant or the exact depth to be accurately known. Fig. 9 shows an acoustic release that has been modified to become a mechanical bulb breaker that overcomes these shortcomings. This bulb breaker is electrically triggered, has an accurate

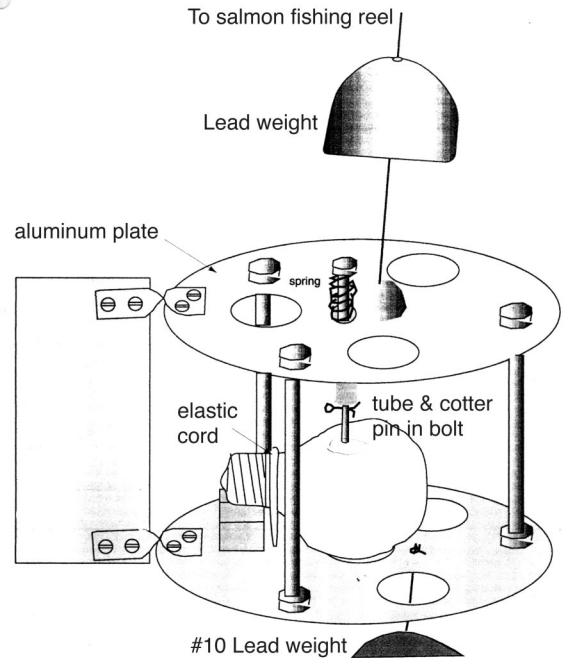

Fig. 8 An easily made light weight bulb breaker. This breaker is raised and lowered with the aid of a large fishing reel and is suitable for use on small boats.

pressure sensor for depth determination, a calibrated hydrophone at a fixed distance for signal recording, the ability to measure filament resistance, and the option of having other electrically driven sources or sensors suspended on the same cable. The drawback of this device is that it is heavy and requires a winch to be operated.

VII. VARIABILITY

In this section we discuss the variability in light bulb crush pressures, SL, and primary resonant frequency.

Light bulbs are manufactured for a specific purpose far removed from the application to which we have been applying them in this paper. Most light bulbs do the job they were intended for with remarkable consistency, unfortunately, when they are used as acoustic sources the results are far less consistent. Even within a given brand and particular model of bulb it has been found that the crush pressure can vary by as much as 100%. This means that a number of freely falling bulbs of the same type cannot be relied on to fail at the same depth. In general, though it is possible to identify various brands of bulbs that will implode in particular depth ranges most of the time. Even this small degree of consistency allows researchers to select the appropriate type of light bulb for the given application. For instance, appliance and decorator bulbs are ideal for use in mechanical breakers when a relatively deep implosion is required. The very least expensive Canadian Tire brand are suitable for free-falling bulbs in water less than 100 m deep.

The measured bulb-to-bulb SL variation appears to be less than 5 dB when the light bulbs are allowed to free-fall to their crush depth. This variation is partially due to the variation in the crush depth which alters the available potential energy. The variation in SL is also likely due in part to the variation in the strength

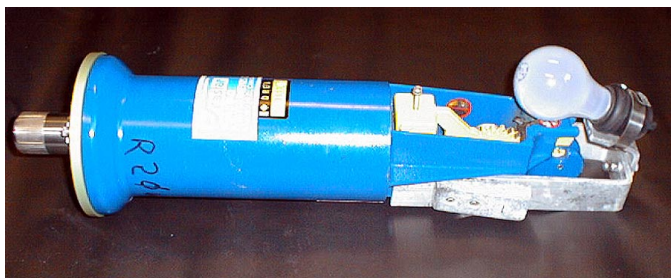

Fig. 9 A mechanical bulb breaker made from a modified acoustic release.

and mass of glass from bulb to bulb. Large variations in the SL can occur when the bulbs fail in different ways, but the indications are that this is a relatively rare occurrence that might be most common with the stronger bulbs such as the decorator globes and appliance bulbs. When bulbs are suspended at a given depth and mechanically broken, the SL variation is smaller than when bulbs are allowed to free-fall.

The primary resonant frequency of an imploding light bulb varies in a predictable way with the depth of the implosion; however, individual measurements of the resonant frequency do show a degree of scatter which probably reflects the variations in the bubble formation. The variation in the resonant frequency appears to be about 25% of the expected value at the given depth, but the overall spectral shape is quite similar from bulb to bulb.

VIII. CONCLUSIONS

In this paper we have discussed the use of light bulbs as acoustic sources. The results of pressure tank tests, physical measurements, calibration barge measurements, and sea test measurements have been presented. We have also collected measurements made by others and compared them with the current set of measurements.

Physical measurements of the various types of light bulbs tested will aid researchers in selecting bulbs for their own experiments.

The variation of the primary resonant frequency for A19 sized bulbs is given by (1). The variation of the radiated SL as a function of depth for standard A19 sized bulbs has been shown to be well described by a simple rule of thumb (2). These two relationships are primary importance in using light bulbs as underwater acoustic sources.

We have also presented the details of three different deployment mechanisms for light bulbs. Other researchers will undoubtedly benefit from the ideas presented and come up with their own techniques.

The variability in the observed crush depths, frequencies, and source levels for light bulbs of the same type is disappointing and makes light bulbs less useful, but does not preclude their use as acoustic sources. Freely falling bulbs should only be used in the less critical applications. Bulbs broken in mechanical devices are more reliable and should be of use in almost all situations.

Finally, light bulbs produce a high peak level, but the total energy available is much less than that produced by small ex-

plosives. The reduced level will make the use of light bulbs appealing to environmentalists as will the reduced contaminants released when a light bulb implodes as compared with an explosive. Unfortunately, the reduced energy level will limit the use of light bulbs in some applications where high losses are incurred or high signal-to-noise ratios are required.

ACKNOWLEDGEMENTS

The authors would like to express their sincere thanks to Dick Shockley and Tom Gabrielson who allowed us to use their light bulb implosion information in this paper. We would also like to express our sincere thanks to Michael Haggarty and Wayne Higgins who spent many hours at the calibration barge and pressure tank facilities testing light bulbs.

REFERENCES

- [1] Acoustic signatures from deep water implosions of spherical cavities. Marshall Orr and Michael Schoenberg. *J. Acoust. Soc. Am.* 59, 1155—1159, 1976.
- [2] Implosions as sources of underwater sound. R.J. Urlick. *J. Acoust. Soc. Am.* 35, 2026—2027, 1963.
- [3] Private communication. T.B. Gabrielson, Applied Research Laboratory, The Pennsylvania State University, 1997.
- [4] Private communication. R.C. Shockley, NCCOSC RDT&E Div., San Diego, Ca, 1997.
- [5] Acoustic signatures of imploding underwater light bulbs. William J. Marshall Jr., presented at the 126th meeting of the Acoustical Society of America, Denver, Oct. 7, 1993.
- [6] Gas bubbles as sources of sound in liquids. M. Strasberg. *J. Acoust. Soc. of Am.* 28, 20—26, 1956.
- [7] Source levels of shallow explosive charges. N.R. Chapman. *J. Acoust. Soc. Am.* 84, 697—702, 1988.
- [8] Acoustic effects of underwater explosive discharges. P.R. Staal. in *Proc. of the Workshop on the Effects of Explosives Use in the Marine Environment*, 29—31 Jan. 1985.